

SINCERT



SISTEMA QUALITÀ CERTIFICATO
UNI EN ISO 9001:2000



ANCCP
Organismo Notificato CE 0302
N° SQU 132A0252/2

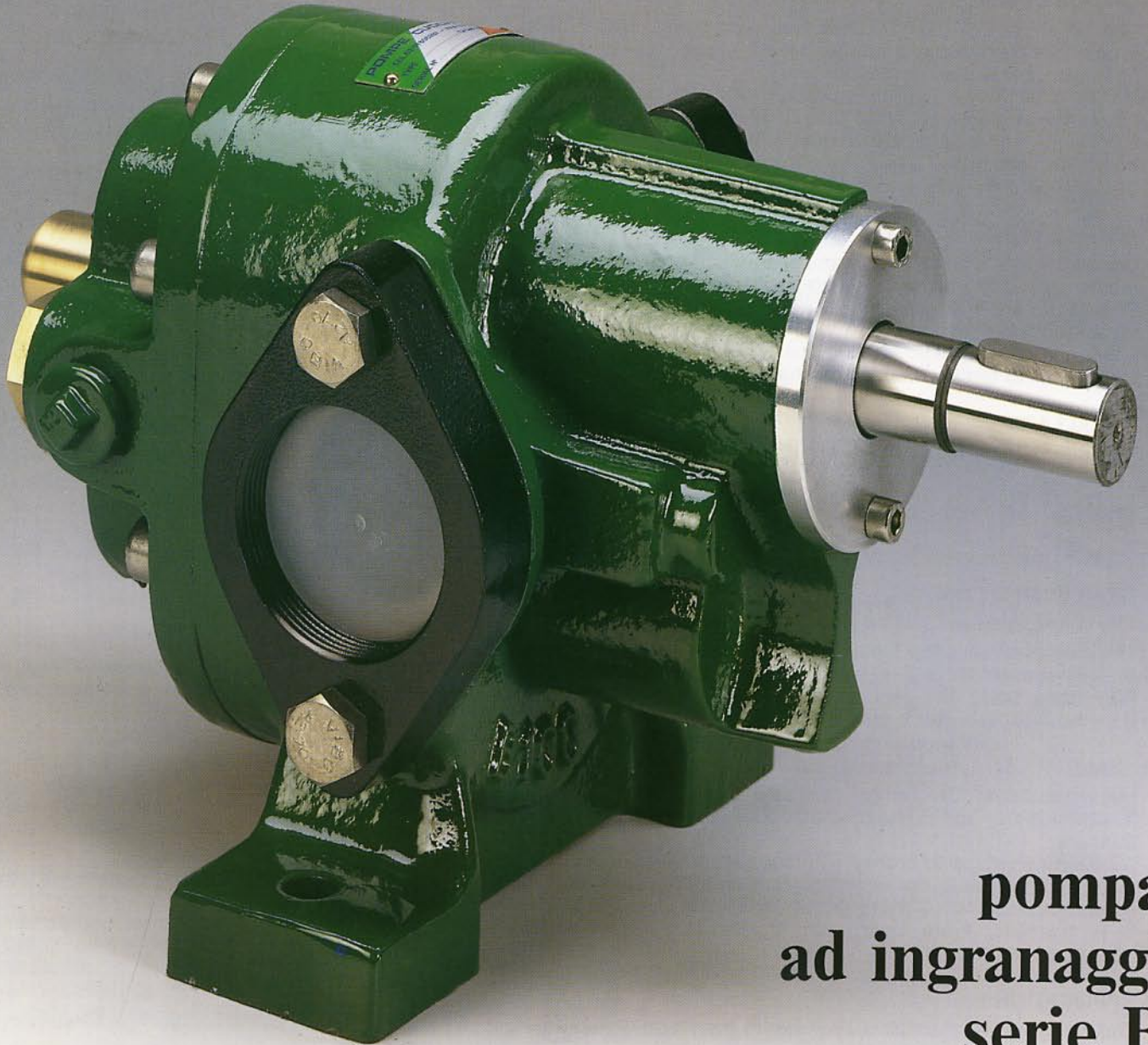

**pompa
ad ingranaggi
serie B**

**gear pumps
set B**

**pompe
à engranages
serie B**

**Zahnradpumpen
der Serie B**



QUALITY SYSTEM CERTIFICATE
OF CONFORMITY TO THE
DIRECTIVE 98/37/CE
Certificate N. SQU132AC010



POMPE AD INGRANAGGI SERIE B

Le pompe volumetriche ad ingranaggi di questa serie sono utilizzate per il trasferimento di liquidi fino a 10 bars.

Le esecuzioni standard sono le seguenti:

- B** - corpo e coperchio in ghisa - ingranaggi ed alberi in acciaio al carbonio - bypass in ottone - supportazione con boccole in materiale sinterizzato autolubrificante.
- BZ** - corpo, coperchio e ingranaggi in bronzo - alberi in acciaio inox aisi 316 - bypass in ottone - supportazione come esecuzione B.
- BX** - corpo - coperchio - ingranaggi, alberi e bypass in aisi 316 - boccole in P.T.F.E. caricato o grafite.

ORGANI DI TENUTA:

Tenuta meccanica (C) - Tenuta meccanica doppia (CC) - Baderna (B).

È possibile l'applicazione di una camera di preriscaldamento (CP).

Esempio di scelta del modello:

BZ 100/BCP pompa in bronzo portata 100 l/min. con tenuta a baderna e camera di preriscaldamento.

Le pompe ad ingranaggi tipo B sono allineabili su base, mediante giunto elastico, a motori - riduttori - motovariatori.

È possibile inoltre applicare un quadro elettronico con contaimpulsi digitale e contatto di prossimità per dosare stesse quantità di prodotto.

Pompa dosatrice ad ingranaggi.

APPLICAZIONI

Questa serie trova largo impiego per trasferimenti di olii - nafte - gasoli - grassi preriscaldati - adesivi - colle - vernici - resine - melasse - sciroppi - shampoo - isocianati, ecc.

Portate: da 5 a 600 l/min.

Pressioni: fino a 10 bars.

Limite max di viscosità: 100.000 cps.

Limite max di temperatura (a richiesta): 300°C.

INSTALLAZIONE

Richiedere il nostro libretto di istruzioni per l'installazione e la manutenzione.



GEAR PUMPS TYPE "B"

The volumetric gear pumps type B are utilized to transfer liquids up to 10 bars.

The executions are the following:

- B** - body and cover in cast iron - gears and shafts in carbon steel - bypass valve in brass - self lubricating sinterized bushes.
- BZ** - body, cover and gears in bronze - shafts in stainless steel AISI 316 - bypass valve in brass - bushes as type B.
- BX** - body, cover, gears, shafts and bypass valve in stainless steel AISI 316. Bushes in P.T.F.E. or graphite.

SEALS

Mechanical seal (C) - Double mechanical seal (CC) - Packing rings (B).

It is possible to add preheating chamber (CP).

Example:

BZ 100/BCP: pump in bronze with capacity 100 l/min. packing rings preheating chamber.

Gear pumps type B, are available, on base plate, aligned by flexible coupling, with motors, reduction gears, variable speed motors, etc.

It is possible, more over, add an electronic console with digital revolution counter to meter the same quantities of liquid.

APPLICATIONS

This range of gear pumps is available to transfer oil - naphta - fuel oil - preheated grease - adhesive - glue - varnish - resin - molasses - syrup - etc.

Capacity: from 5 to 600 l/min.

Pressure: up to 10 bars.

Maximum viscosity: 100.000 cps.

Maximum temperature (on request): 300°C.

INSTALLATION

Please ask our installation, operation and maintenance instructions manual.



ZAHNRADPUMPEN DER SERIE B

Volumetrische Zahnradpumpen der Serie B werden für die Förderung von Flüssigkeiten bis zu 10 bar Druck verwendet.

Die Standardausführungen sind:

- B** - Deckelkörper aus Gußeisen - Getriebe und Wellen aus Kohlenstoffstahl, Bypass aus Messing - Lager aus gesintertem, selbstschmierendem Material.
- BZ** - Deckelkörper und Getriebe aus Bronze - Wellen aus rostfreiem AISI 316-Stahl, Bypass aus Messing, Lager wie bei B.
- BX** - Deckelkörper - Getriebe, Wellen und Bypass aus AISI 316, Lager aus P.T.F.E. oder Graphit.

DICHTUNGEN

Mechanische Dichtung (C) - doppelte mechanische Dichtung (CC) - Packung (B).

Eine Vorwärmekammer (CP) ist möglich.

Beispiel einer Modellwahl:

BZ 100/BCP Pumpe aus Bronze, Fördermenge 100 l/min. mit Packungsdichte und Vorwärmekammer.

Die Zahnradpumpen des Typs B können auf Sockel montiert, reihenförmig mittels elastischem Verbindungsstück an Motoren-Umsetzungsgetriebe-Motor-Drehzahlregler angeschlossen werden.

Außerdem kann ein elektronisches Schaltpult mit Digital-Impulszähler und Annäherungskontakt für die Dosierung derselben Produktmenge installiert werden.

ANWENDUNGSBEREICHE

Diese Serie wird weitgehend für den Transport von Ölen, Naphta, Dieselöl, vorgewärmten Fetten, Klebstoffen, Lacken, Harzen, Melassen, Syrup, Shampoo, Isozyanat usw. verwendet.

Fördermenge: von 5 bis 600 l/min.

Drucke: bis zu 10 Bar.

Maximale Viskositätsgrenze: 100.000 cps.

Maximale Temperaturgrenze (auf Wunsch): 300°C.

INSTALLATION

Fordern Sie bitte unsere Bedienungsanweisungen für die Installation und Wartung an.



POMPES A ENGRENAGES SERIE B

Les pompes volumétriques à engrenages de cette série sont utilisées pour le transfert des liquides jusqu'à 10 bars.

Les fabrications standards sont les suivantes:

- B** - corps et couvercle en fonte - engrenages et arbres en acier au carbone - by-pass en laiton - palier avec coussinets en matériel autolubrifiant.
- BZ** - corps, couvercle et engrenages en bronze - arbre en acier inox 316 - by-pass en laiton - palier avec coussinets en matériel autolubrifiant.
- BX** - corps, couvercle, engrenages, arbres, by-pass en acier inox 316 - coussinets en P.T.F.E. chargés ou graphite.

ORGANES D'ETANCHEITE

Garniture mécanique simple (C) - Garniture mécanique double (CC) - Tresses (B) - Il est possible d'avoir une chambre de préchauffage (CP).

Exemple de choix d'un modèle:

BZ 100/BCP pompe en bronze, débit 100 l/min avec étanchéité à tresse et chambre de préchauffage.

Les pompes à engrenages de type B peuvent être montées en groupe sur châssis avec moteurs, réducteurs, moto-variateurs.

En plus, il y a possibilité de monter un compteur d'impulsion digital et un contacteur de proximité pour doser parfaitement la quantité de produit.

APPLICATIONS

Cette série de pompes trouve leur application dans le transfert des huiles, mazout, gas-oil, matières grasses préchauffées, colles vernis, mélasses, sirops, shampoings, isocyanates, etc...

Débit: de 5 à 600 l/min

Pression: jusqu'à 10 bars

Limite max. de viscosité: 100.000 cps

Limite max. de température: 300°C (à la demande).

INSTALLATION

Demander la brochure d'instructions pour l'installation et la manutention.



DATI CARATTERISTICI RIFERITI A 1450 giri/min. - OLIO 6°E
 PERFORMANCE DATA AT 1450 r.p.m. - OIL VISCOSITY 6°E
 TECHNISCHE MERKMALE BEI 1450 rpm - ÖL-VISKOSITÄT 6°E
 DONNÉES CARACTÉRISTIQUES À 1450 Tr/min - HUILE 6°E

TIPO TYPE TYP TYPE	FLANGIE FLANGES FLANSCH ORIFICE	PORTATA L/MIN - PREVALENZA M. CAPACITY L/MIN - PRESSURE MT. FÖRDERMENGE L/MIN - FÖRDERHÖHE M. DEBIT L/MIN - PRESSION M.				ASSORBIMENTO HP - PREVALENZA M. HP ABSORBED - PRESSURE MT. PS - BEDARD - FÖRDERHÖHE M. PUISSANCE ABSORBÉE HP - PRESSION M.				N.P.S.H.
		25	50	75	100	25	50	75	100	
		25	50	75	100	25	50	75	100	4
B 5	1/2"	6	5,9	5,7	5,5	0,20	0,23	0,26	0,30	4
B 10	1/2"	12,5	12	11,5	11,5	0,25	0,30	0,35	0,45	4
B 15	3/4"	18,5	18	17,5	17,5	0,30	0,35	0,45	0,55	4
B 25	3/4"	25	24	23	22	0,40	0,50	0,70	0,80	4
B 40	1"	43	42	41	40	0,60	1,00	1,20	1,50	4
B 50	1 1/2"	55	53	51	50	0,70	1,20	1,50	1,80	4
B 70	1 1/2"	77	75	74	72	1,00	1,65	2,00	2,30	4
B 100	2"	114	110	105	100	1,20	2,00	2,70	3,70	4
B 150	2"	166	162	158	153	1,60	2,70	4,00	5,50	4
B 200	2 1/2"	215	212	208	205	2,20	3,70	5,50	7,50	5
B 250	2 1/2"	265	261	255	251	2,50	4,50	7,00	9,00	5
B 300	2 1/2"	320	314	306	300	3,00	5,00	7,50	10,0	5
B 350	2 1/2"	371	365	359	352	3,30	6,00	8,80	12,0	5
B 400	2 1/2"	418	415	411	406	3,70	6,70	10,0	13,0	5
B 450	3"	472	468	459	453	3,90	8,00	11,0	15,0	5
B 500	3"	525	515	510	505	4,50	8,50	12,6	16,0	5
B 550	3"	570	560	550	546	5,00	9,20	13,8	18,5	5
B 600	3"	625	619	614	609	5,50	10,0	15,0	20,2	5

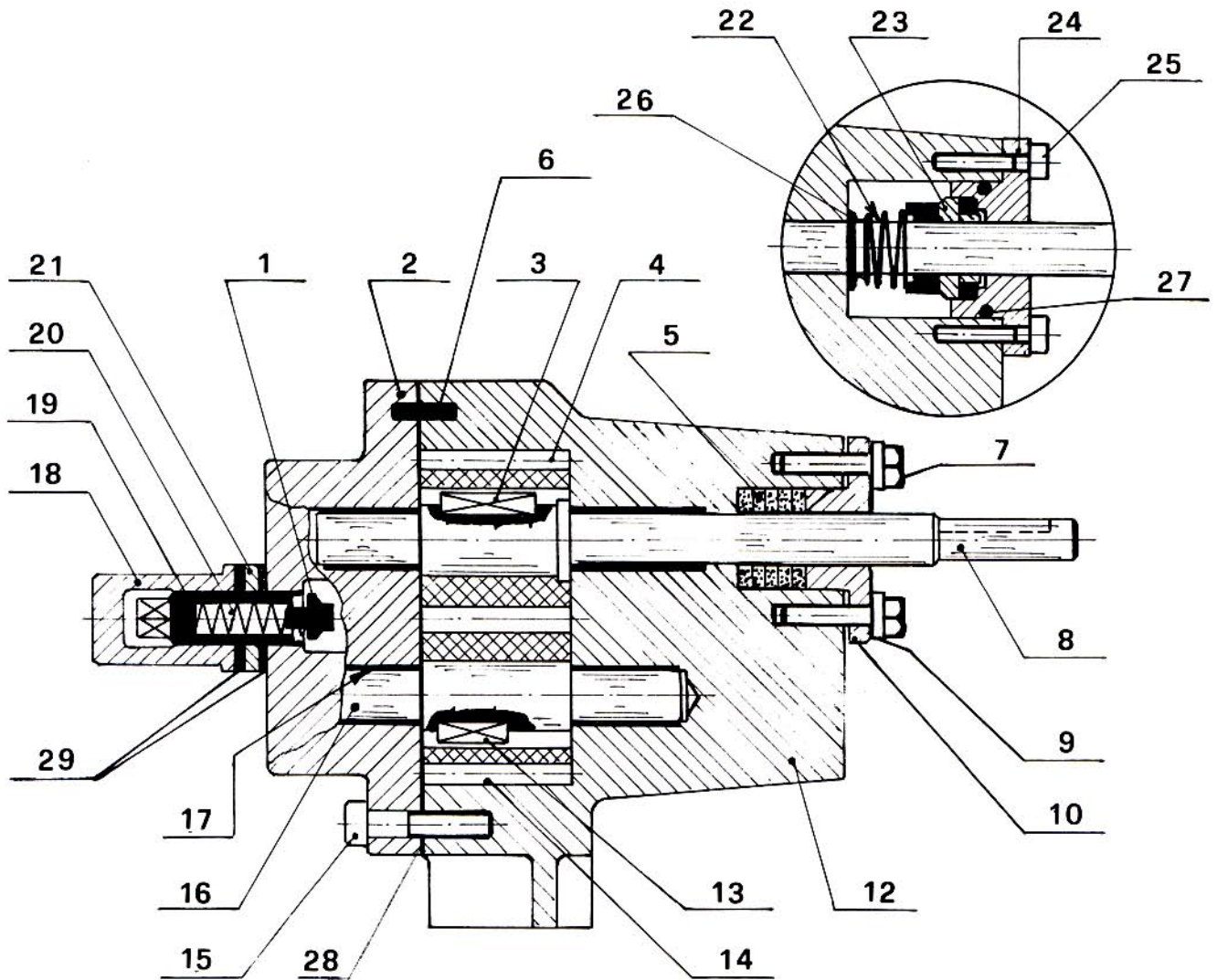

NOMENCLATURA B5-B150

- 1 Tastatore
- 2 Coperchio
- 3 Chiavetta albero conduttore
- 4 Ingranaggio conduttore
- 5 Baderna
- 6 Spina
- 7 Vite T.E.
- 8 Albero conduttore
- 9 Rondella
- 10 Premitreccia
- 12 Corpo
- 13 Chiavetta albero condotto
- 14 Ingranaggio condotto
- 15 Vite T.C.C.E.
- 16 Albero condotto
- 17 Boccole di supportazione
- 18 Corpo bypass
- 19 Ghiera di regolazione
- 20 Molla
- 21 Controdado
- 22 Tenuta meccanica dinamica
- 23 Tenuta meccanica statica
- 24 Premi tenuta meccanica
- 25 Vite T.C.C.E.
- 26 Seeger
- 27 OR
- 28 Guarnizione
- 29 Guarnizione

PARTS LIST B5-B150

- 1 Feeler
- 2 Cover
- 3 Driving shaft key
- 4 Driving gear
- 5 Packing
- 6 Pin
- 7 Screw
- 8 Driving Shaft
- 9 Washer
- 10 Stuffing box head
- 12 Body
- 13 Driven shaft key
- 14 Driven gear
- 15 Hex. cyl. head screw
- 16 Driven shaft
- 17 Bush
- 18 Valve body
- 19 Adjusting screw
- 20 Spring
- 21 Jam nut
- 22 Dynamics mechanical seal
- 23 Statics mechanical seal
- 24 Mechanical seal cover
- 25 Hex. cyl. hollow head screw
- 26 Seeger
- 27 O-ring
- 28 Gasket
- 29 Gasket

TEILLISTE B5-B150

- 1 Fühler
- 2 Deckel
- 3 Paßfeder - Antriebswelle
- 4 Antriebsrad
- 5 Packung
- 6 Stift
- 7 Sechskantschraube
- 8 Antriebswelle
- 9 Unterlegscheibe
- 10 Stopfbuchse
- 12 Gehäuse
- 13 Paßfeder - Antriebswelle
- 14 Antriebsrad
- 15 Innensechskantschraube
- 16 Antriebswelle
- 17 Lager
- 18 Bypass - Gehäuse
- 19 Stellschraube
- 20 Feder
- 21 Gegenmutter
- 22 Dynamische mechanische Dichtung
- 23 Statische mechanische Dichtung
- 24 Mechanischer Dichtungsdeckel
- 25 Innensechskantschraube
- 26 Stützscheibe
- 27 O-Ring
- 28 Dichtung
- 29 Dichtung

NOMENCLATURE DE LA B5 A B150

- 1 Clapet
- 2 Couvercle
- 3 Clavette
- 4 Engrenage commandeur
- 5 Tresses
- 6 Goupille
- 7 Écrou
- 8 Arbre commandeur
- 9 Goujons
- 10 Fouloir presse-étoupe
- 12 Corps
- 13 Clavette
- 14 Engrenage commandé
- 15 Vis CHC
- 16 Arbre commandé
- 17 Coussinet
- 18 Corps de by-pass
- 19 Vis de réglage
- 20 Ressort
- 21 Contre-écrou
- 22 Grain tournant de la garniture mécanique
- 23 Grain fixe de la garniture mécanique
- 24 Presse garniture
- 25 Vis CHC
- 26 Circlips
- 27 Joint torique
- 28 Joint plat
- 29 Joint plat

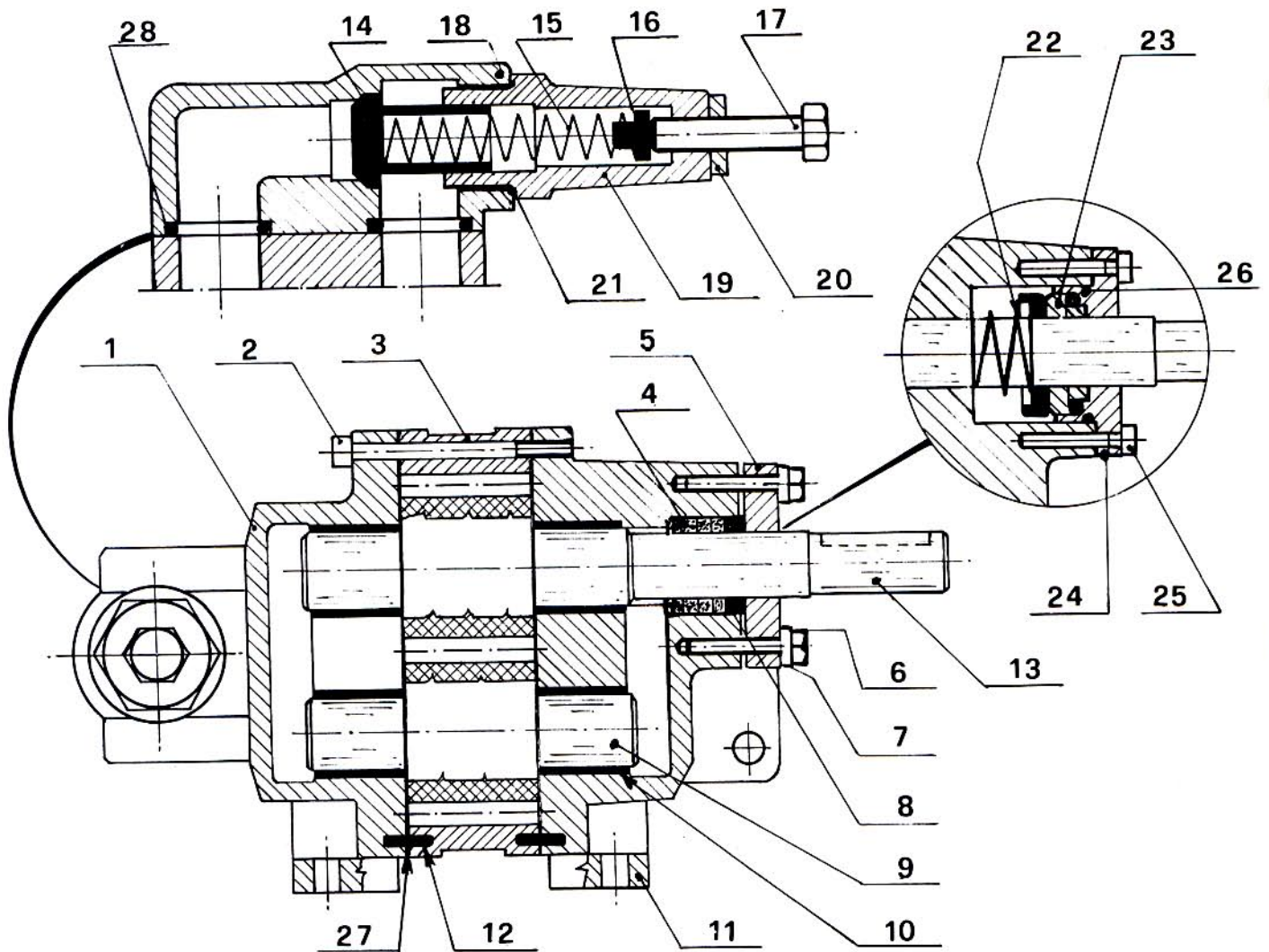

NOMENCLATURA B200-B600

- 1 Coperchio
- 2 Vite T.C.C.E.
- 3 Corpo
- 4 Baderna
- 5 Premitreccia
- 6 Vite T.E.
- 7 Rondella
- 8 Ghiera
- 9 Pignone
- 10 Boccola di supporto
- 11 Coperchio flangiato
- 12 Spina
- 13 Pignone conduttore
- 14 Tastatore
- 15 Molla
- 16 Vite d'appoggio
- 17 Vite di regolazione
- 18 Corpo bypass
- 19 Contenitore
- 20 Controdado
- 21 OR
- 22 Tenuta meccanica dinamica
- 23 Tenuta meccanica statica
- 24 Premitenuta meccanica
- 25 Vite T.C.C.E.
- 26 OR
- 27 Guarnizione
- 28 OR

PARTS LIST B200-B600

- 1 Cover
- 2 Hex. cyl. Hollow head screw
- 3 Body
- 4 Packing
- 5 Stuffing box head
- 6 Screw
- 7 Washer
- 8 Ring
- 9 Driven pinion
- 10 Bush
- 11 Flanged cover
- 12 Pin
- 13 Driving pinion
- 14 Feeler
- 15 Spring
- 16 Contact screw
- 17 Adjusting screw
- 18 Valve body
- 19 External valve body
- 20 Jam nut
- 21 O-ring
- 22 Dynamics mechanical seal
- 23 Statics mechanical seal
- 24 Mechanical seal cover
- 25 Nex. cyl. Hollow head screw
- 26 O-ring
- 27 Gasket
- 28 O-ring

TEILLISTE B200-B600

- 1 Deckel
- 2 Innensechskantschraube
- 3 Körper
- 4 Packung
- 5 Stopfbuchse
- 6 Sechskantschraube
- 7 Unterlegscheibe
- 8 Nutmutter
- 9 Antriebsritzel
- 10 Lager
- 11 Flanschdeckel
- 12 Stift
- 13 Antriebsritzel / Welle
- 14 Fühler
- 15 Feder
- 16 Kontaktschraube
- 17 Stellschraube
- 18 Bypass - Körper
- 19 Ventilgehäuse
- 20 Gegenmutter
- 21 O-Ring
- 22 Dynamische mechanische Dichtung
- 23 Statische mechanische Dichtung
- 24 Mechanischer Dichtungsdeckel
- 25 Innensechskantschraube
- 26 O-Ring
- 27 Dichtung
- 28 O-Ring

NOMENCLATURE B200-B600

- 1 Couvercle
- 2 Vis CHC
- 3 Corps
- 4 Tresses
- 5 Presse-étoupe
- 6 Écrou
- 7 Goujon
- 8 Bague
- 9 Pignon commandé
- 10 Coussinet
- 11 Couvercle
- 12 Coupille
- 13 Pignon commandeur
- 14 Clapet
- 15 Ressort
- 16 Butée
- 17 Vis de réglage
- 18 Corps de by-pass
- 19 Support
- 20 Contre écrou
- 21 Joint torique
- 22 Grain tournant de la garniture mécanique
- 23 Grain fixe de la garniture mécanique
- 24 Presse Garniture
- 25 Vis CHC
- 26 Joint torique
- 27 Joint plat
- 28 Joint torique

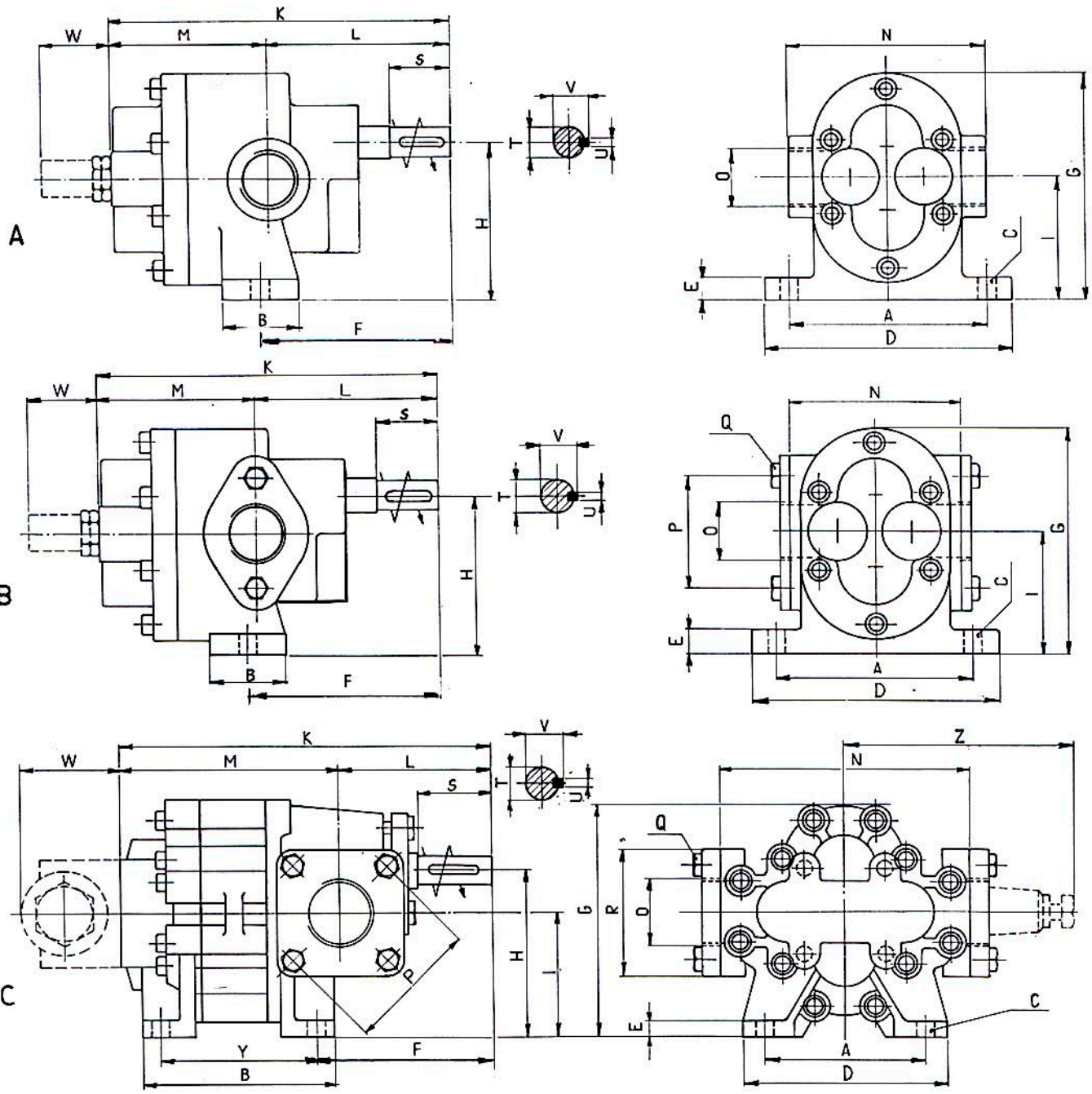

GRUPPO SET AGGREGAT GROUPE	TIPO TYPE TYP TYPE	A	B	C	D	E	F	G	H	I	K	L	M	N	O	P	Q	R	S	T	U	V	W	Y	Z	PESO KG WEIGHT GEWICHT POIDS
A	B 5	106	35	11,5	130	12	100	117	80	64	160	100	60	88	1/2" *	-	-	-	28	12	4	14	47	-	-	2,9
	B 10	106	35	11,5	130	12	100	117	80	64	170	100	70	88	1/2" *	-	-	-	28	12	4	14	47	-	-	3,22
	B 15	106	40	11,5	130	12	120	117	80	64	180	120	60	88	3/4"	-	-	-	28	12	4	14	47	-	-	3,6
	B 25	106	40	11,5	130	12	116	117	80	64	190	116	74	88	3/4"	-	-	-	28	12	4	14	47	-	-	3,9
	B 40	125	45	12	155	15	150	139	97	77	235	150	85	122	1"	-	-	-	40	15	5	18	47	-	-	7
B	B 50	125	50	12	156	18	158	160	114	92	235	150	85	100	1 1/2"	75	M10	-	40	15	5	18	47	-	-	9,94
	B 70	125	50	12	156	18	158	160	114	92	245	150	95	100	1 1/2"	75	M10	-	40	15	5	18	47	-	-	10,1
	B 100	162	62	13	200	22	173	205	142	111	261	160	101	135	2"	92	M12	-	40	24	8	27	54	-	-	17,7
	B 150	162	62	13	200	22	173	205	142	111	281	160	121	135	2"	92	M12	-	40	24	8	27	54	-	-	20,4
C	B 200	140	150	13	170	16	147	200	142	105	305	125	180	210	2 1/2"	115	M12	110	60	28	8	31	74	120	210	27,3
	B 250	140	162	13	170	16	147	200	142	105	317	125	192	210	2 1/2"	115	M12	110	60	28	8	31	74	132	210	33
	B 300	140	174	13	170	16	147	200	142	105	329	125	204	210	2 1/2"	115	M12	110	60	28	8	31	74	144	210	35
	B 350	140	186	13	170	16	147	200	142	105	341	125	216	210	2 1/2"	115	M12	110	60	28	8	31	74	156	210	36,5
	B 400	140	200	13	170	16	147	200	142	105	355	125	230	210	2 1/2"	115	M12	110	60	28	8	31	74	170	210	38
	B 450	192	174	14,5	220	20	190	258	188	140	370	148	222	260	3"	118	M12	124	55	32	10	39	104	140	250	45
	B 500	192	183	14,5	220	20	190	258	188	140	379	148	231	260	3"	118	M12	124	55	32	10	39	104	149	250	48
	B 550	192	192	14,5	220	20	190	258	188	140	388	148	240	260	3"	118	M12	124	55	32	10	39	104	158	250	51
B 600	192	201	14,5	220	20	190	258	188	140	397	148	249	260	3"	118	M12	124	55	32	10	39	104	167	250	55	

* 3/4" BX (AISI 316) Dimensioni e pesi non impegnativi Approximate dimensions and weights Abmessungen und Gewichte sind Richtwerte Dimensions et poids sans engagement

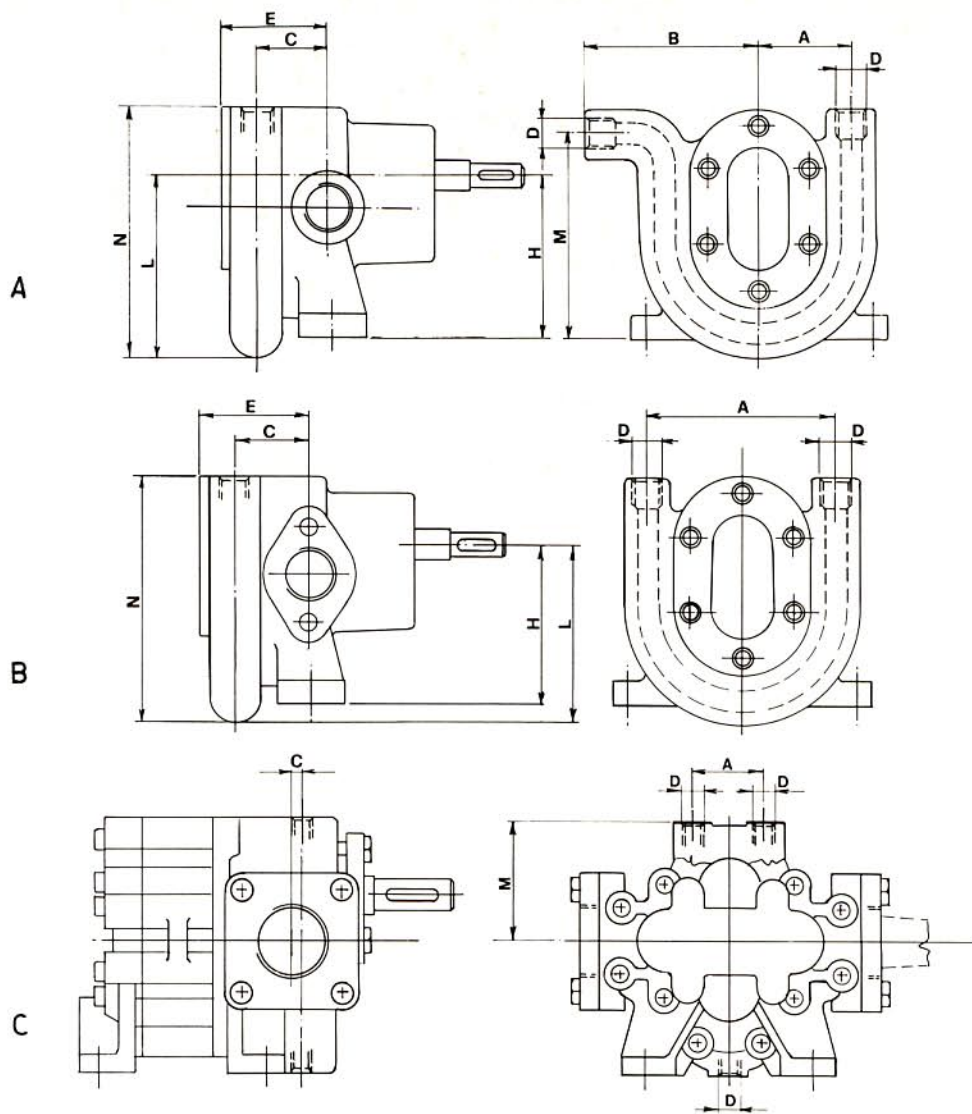

SET AGGREGAT GROUPE	GRUPPO TYPE TYP TYPE	TIPO A	B	C	D	E	H	L	M	N
A	B 5	50	75	42	1/2"	61	80	96	91	129
	B 10	50	75	52	1/2"	71	80	96	91	129
	B 15	50	75	44	1/2"	63	80	96	91	129
	B 25	50	75	54	1/2"	73	80	96	91	129
B	B 50	130	-	69	3/4"	91	114	130	-	175
	B 70	130	-	79	3/4"	101	114	130	-	175
	B 100	160	-	76	1"	104	142	167	-	225
	B 150	160	-	96	1"	124	142	167	-	225
C	B 200	64	-	1	3/4"	-	-	-	85	-
	B 250	64	-	1	3/4"	-	-	-	85	-
	B 300	64	-	1	3/4"	-	-	-	85	-
	B 350	64	-	1	3/4"	-	-	-	85	-
	B 400	64	-	1	3/4"	-	-	-	85	-
	B 450	50	-	1,5	1"	-	-	-	135	-
	B 500	50	-	1,5	1"	-	-	-	135	-
	B 550	50	-	1,5	1"	-	-	-	135	-
B 600	50	-	1,5	1"	-	-	-	135	-	

Pompe con camera di preriscaldamento

Pumps with heating chamber

Pumpen mit vorwärmekammer

Pompes avec chambre de chauffage

pompe cucchi



20090 OPERA (MI) ITALY - VIA DEI PIOPPI, 39 - TEL. ++39 2 57.60.62.87 (R.A.) - FAX ++39 2 57.60.22.57

<http://www.pompecucchi.it> <http://www.pompecucchi.com> e-mail cucchi@pompecucchi.it