



Gear Wheel Flowmeter for Viscous Liquids



measuring
•
monitoring
•
analysing

DOM



- Measuring range:
0.5...36 L/h and 150...2500 L/min
- Viscosity range: 0...1000 cP
(higher with special cut rotors)
- Accuracy: $\pm 0.2\%$...1% of reading
- Material: aluminium, ductile iron or stainless steel
- p_{\max} : 400 bar; t_{\max} : 120 °C
- Pulse output, LCD display, 4...20 mA, alarms, mechanical register

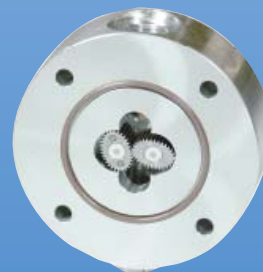

KOBOLD companies worldwide:

ARGENTINA, AUSTRIA, BELGIUM, BULGARIA, CANADA, CHILE, CHINA, COLUMBIA, CZECHIA, DOMINICAN REPUBLIC, EGYPT, FRANCE, GERMANY, GREAT BRITAIN, HUNGARY, INDIA, INDONESIA, ITALY, MALAYSIA, MEXICO, NETHERLANDS, PERU, POLAND, ROMANIA, SINGAPORE, SOUTH KOREA, SPAIN, SWITZERLAND, TAIWAN, THAILAND, TUNISIA, TURKEY, USA, VIETNAM

KOBOLD Messring GmbH
Nordring 22-24
D-65719 Hofheim/Ts.
Head Office:
+49 (0) 6192 299-0
+49 (0) 6192 23398
info.de@kobold.com
www.kobold.com

Principle of Operation

The Oval Gear meters are positive displacement flowmeters where the passage of liquid causes two oval gears to rotate within a precision measuring chamber and with each rotation a fixed volume of liquid passes through the meter. Magnets embedded within the gears initiate a high resolution pulse train output. The pulse output can be wired directly to process control and monitoring equipment or can be used as an input to instruments supplied with or fitted directly onto the meter.

The flowmeter is available as a blind transmitter with pulse output capable of interfacing to most monitoring and control instrumentation or the meter can be fitted with or supplied with instruments such as totalisers, rate totalisers or batch controllers. These instruments also have monitoring and control output options including 4-20 mA, scaled pulse, flowrate alarms and batch control logic (preset metering).

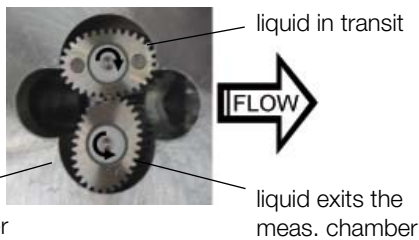

This technology allows precise flow measurement and dispensing of most clean liquids regardless of their conductivity, with other liquid characteristics having no or minimal effect on meter performance. This metering technology does not require flow profile conditioning or straightline runs as required with alternative flow technologies making the installation relatively compact and low cost.

Positive displacement flowmeters are an inexpensive means to accurately meter high viscosity clean liquids as high as 1 million centipoises however, the appropriate meter must be sized so that the pressure drop across the primary measuring elements (oval rotor), does not exceed the maximum capability of either.

Areas of Application

For all viscous, non abrasive clean liquids like:

- Petroleum
- Oil
- Chemicals
- Grease
- Fuels
- Ink etc.
- Pastes
- Water

Stainless steel flowmeters are suited to most water based products and chemicals and aluminum meters are suitable for fuels, fuel oils & lubricating liquids.

Technical Details

Material

DOM-A05 ... DOM-A15

- Body: aluminium
- Gear wheels: stainless steel 1.4401 (SS 316)
- Bearing: ceramic

DOM-A20... DOM-A60

- Body/flanges: aluminium
- Gear wheels: aluminium
- Bearing: hardened steel rollers (only for lubricating fuels or oil)

DOM-S, DOM-H

- Body/flanges: stainless steel 1.4401 (SS 316)
- Gear wheels: stainless steel 1.4401 (SS 316)
- Bearing: ceramic

DOM-D

- Body/flanges: ductile iron
- Gear wheels: aluminium
- Bearing: hardened steel rollers (only for lubricating fuels or oil)

O-Rings:

- FPM (standard): -15 ... +120 °C
- EPR (ethylene propylene rubber): -20 ... +120 °C (for ketones only)
- PTFE encapsulated FPM: -20 ... +120 °C
- NBR: -20 ... +100 °C

Cover:

- glass reinforced nylon, stainless steel (options HE, DE)

Accuracy:

- ±1% of reading (DOM-x05...DOM-x15)
- ± 0.5% of reading (DOM-x20...DOM-x35)
- ± 0.2% of reading (DOM-x40...DOM-x60 turndown 15: 1)

Repeatability:

- typ. ± 0.03 %

Protection class:

- IP 66/67

Temperature range:

- 20 °C ... +80 °C for options L0, Z and B and -20 °C ... +120 °C for pulse output, for options Z and B with cooling fins and for option M

Cable entry:

- M20 x 1.5 (standard), ½" NPT adapter (option)

ATEX-approval

(option Z4):

- Ex II 2G EEx ia IIB T4 (-20 °C ≤ Ta ≤ +60 °C)

(option HE, DE):

- Ex II 2G Ex d IIB T6 (-20 °C ≤ Ta ≤ +70 °C)

- Ex II 2G Ex d IIB T4 (-20 °C ≤ Ta ≤ +120 °C)

- Ex I M2 Ex d I Mb (st. steel models only)

Maximum Pressure (threaded version)

Model	Maximum pressure [bar]			
	DOM-A..	DOM-S..	DOM-H..	DOM-D..
DOM-x05..	15	34	400	-
DOM-x10..	15	34	400	-
DOM-x15..	15	34	400	-
DOM-x20..	68 ¹⁾	68 ¹⁾	400	-
DOM-x25..	68 ¹⁾	68 ¹⁾	400	-
DOM-x30..	30	30	400	-
DOM-x35..	20	38 ²⁾	300	-
DOM-x40..	20	-	-	-
DOM-x45..	12	12	-	12
DOM-x50..	12	-	-	-
DOM-x55..	10	-	-	10
DOM-x60..	10	-	-	-

with flanges, maximum pressure rating as above or as per flange rating, whichever is lower

¹⁾ restricted to max. 40 bar with options M1, M3

²⁾ restricted to max. 30 bar with options M1, M3



Recommended Filter

DOM-x05 ... DOM-x15 < 75 µm micron (200 mesh)
 DOM-x20 ... DOM-x35 < 150 µm micron (100 mesh)
 DOM-x40 ... DOM-x60 < 350 µm micron (45 mesh)

Pulse Output

Reed switch pulse output

The reed switch output is a two wire normally open SPST voltage free contact ideal for installations without power or for use in hazardous area locations when Intrinsically Safe (I.S.) philosophy is adopted.

Note: when using the reed switch output the liquid temperature must not change at a rate greater than 10°C per minute. In general the reed switch life will exceed 2 billion actuations when switching less than 5V_{DC}/10 mA.

Power supply: max. 30 V_{DC}, max. 200 mA

Hall effect sensor pulse output

The hall effect sensor is a high resolution solid state 3 wire device providing an unsourced, open collector, NPN transistor output. The term “un-sourced” means that no voltage is applied to the output from within the flowmeter, it must be pulled to a “high” or “on” state by between 5- 24 V_{DC} supplied from an external source, typically the receiving instrument.

The pulse output between signal and -0 V is a voltage square wave with the high level being the DC voltage available at the open collector and the low level being -0 V.

The receiving instrument must incorporate a pull up resistor (typically greater than 10 kΩ in most instruments) which ties the open collector to the available DC voltage level when the hall sensor is not energized. When energized the open collector output is pulled to ground through the emitter (-0 V).

Power supply: max. 5-24 V_{DC}, max. 20 mA

Quadrature hall effect pulse output (...D0)

Two hall effect sensors arranged to give separate outputs out of phase with one another.

The quadrature output is typically suited to custody transfer applications where signal integrity verification is required, it is also used for metering bi-directional flow.

Power supply: max. 8- 24 V_{DC}, max. 20 mA

Mechanical totaliser (...M1 and ...M3)

The flowmeters type DOM-x20 up for DOM-x60 are available with a mechanical totaliser with either 3- or 4-digit resettable totaliser and indication of accumulated total value. The motion of the rotors is transmitted to the mechanical register totaliser via an interfacing reduction gear train and dynamic seal assembly.

Electronic with LCD display

Model	..Z1	..Z3	..Z5	..B1
Function	dual totaliser	rate totaliser	rate totaliser	batch controller
Power source				
battery-powered	yes	yes	yes	no
external (drives output, backlighting)	8- 24 V _{DC}	8- 24 V _{DC}	8- 24 V _{DC}	12- 24 V _{DC}
LCD display				
-line 1/ no. of digits	7.5 mm/5	9 mm/8	17 mm/6	9 mm/8
-line 2/ no. of digits	3.6 mm/8	-	7 mm/8	-
selectable units	yes	yes	yes	yes
decimal point	yes	yes	yes	yes
subscripts displayed	yes	yes	yes	yes
accumulative total	yes	yes	yes	yes
resettable total	yes	yes	yes	no
Linearisation	no	yes	no	no
rate display	no	yes	yes	no
backlighting	no	no	yes	no
Input type				
un-powered sensors	see ZOD datasheet			
powered sensors	see ZOD datasheet			
Outputs				
4-20 mA (750 Ω)	no	yes	no	no
high/low flow alarm	no	NPN/PNP	NPN	no
batch end & control	no	no	no	NPN/PNP
pulse outputs	NPN/PNP	NPN/PNP	NPN	NPN/PNP
2 x SPDT relays	no	optional*	no	optional*
Installation				
IP 66/67	yes	yes	yes	yes
cable entries	1 x gland (meter mount) 2 x glands (remote)	3 x M 20	3 x M 16	3 x M 20
intrinsic safe (option)	no	yes	no	no
mounting	meter mount, wall, pipe or panel mounting			
temperature range	-20 ... +80 °C (Option: -20 ... +120 °C)			

*replaces solid state outputs



Accuracy and Pressure Drop for DOM-x05/10/15...

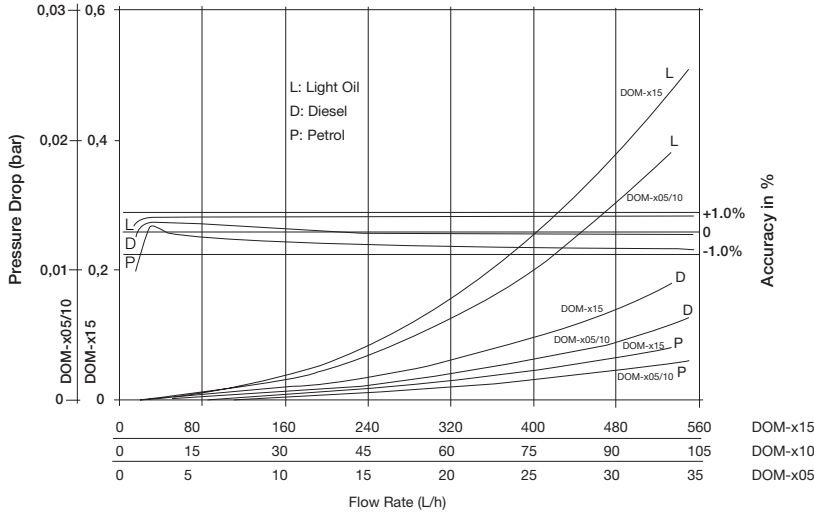

Accuracy and Pressure Drop for DOM-x20... and above

(Note: can also be used for DOM-X05/10/15 for different fluids or viscosities not specifically covered in top graph)

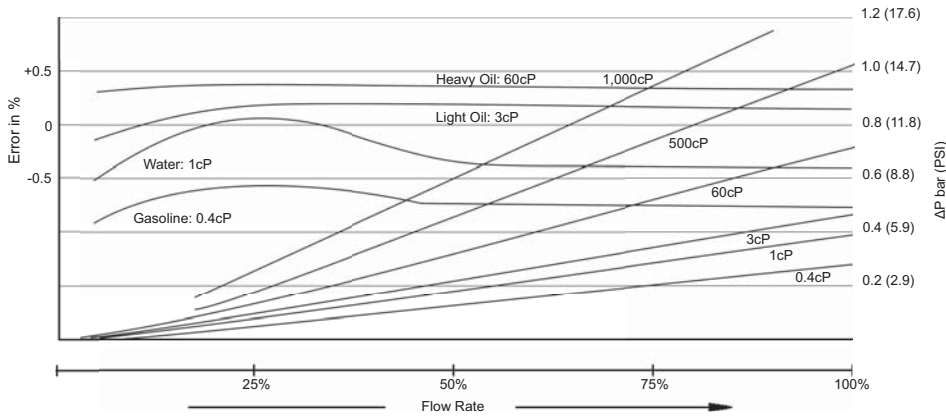

Pressure Drop Curves for Standard and Special Cut Rotors (option "S") in %age of Max. Flow

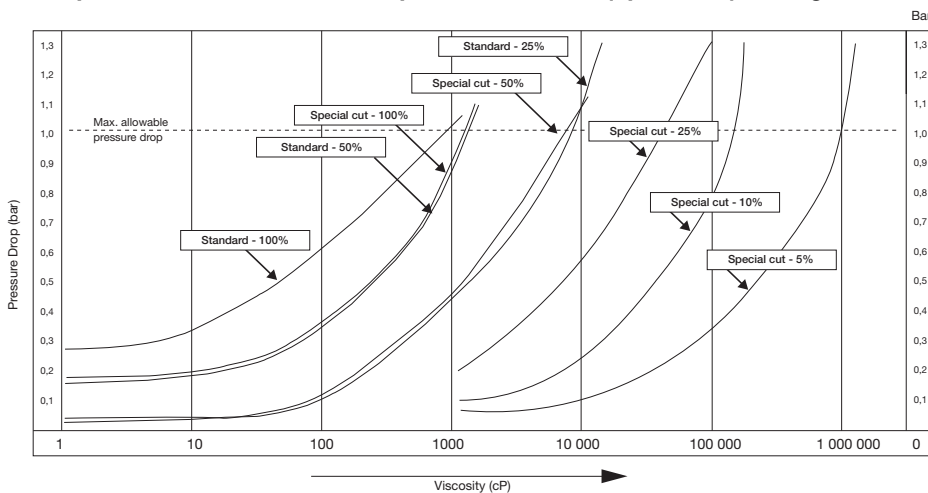

Pressure drop limit verses flowrate

The curves above represent the pressure drop for standard and special cut high viscosity oval rotors at various viscosities. Special cut rotors have alternate tooth relieve which

effectively reduces the pressure drop by 50%. When sizing a meter, be sure your selection falls on or below the 1 bar maximum allowable pressure drop line on the graph.



Maximum Flowrate Multiplier (for higher viscosities)

Viscosities (cP)	Standard rotor	Special cut rotor
≤ 1 000	1	1
≤ 2 000	0.5	1
≤ 4 000	0.42	0.84
≤ 6 000	0.33	0.66
≤ 8 000	0.25	0.5
≤ 30 000	0.15	0.3
≤ 60 000	0.12	0.25
≤ 150 000	0.1	0.2
≤ 250 000	0.05	0.1
≤ 1 000 000	0.025	0.05

Special Cut Rotors for higher viscosities

For viscosity > 1000 cP, special cut rotors option "S" should be used to reduce pressure drop. This applies to DOM-x15 and larger sizes. For higher viscosities, the flowmeter max.

Flowrate is de-rated according to the attached chart. Example: DOM-x25 measuring oil at 8000 cP, max. flow 150 LPM x 0.5 = 75 LPM new maximum flow rate.

Output Pulse Resolution

Model	Measuring range [L/min]	Pulse/litre		
		Reed switch	Hall-sensor	Quadr. hallsensor
DOM-x05	0.5 - 36 L/h	2890	2890	2890
DOM-x10	2 - 100 L/h	1050	1050	1050
DOM-x15	15 - 550 L/h	355	710	710
DOM-x20	1 - 40	83	166	166
DOM-x25	10 - 150	27	107	53.5
DOM-x30	15 - 250	13	52.6	26.3
DOM-x35	30 - 450	6.5	26	13
DOM-x40	50 - 580	4.93	19.73	9.86
DOM-x45	35 - 750	2.32	9.3	4.65
DOM-x50	50 - 1000	1.55	6.2	3.1
DOM-x55	75 - 1500	1.1	4.4	2.2
DOM-x60	150 - 2500	0.56	2.24	1.12

Order Details Thread Connection (Example: DOM-A05H R1 1 H0 0)

Meas. range [L/min]	Connec-tion female	Housing material			O-ring material	Electronics	Option
		Aluminium	Stainless steel	Ductile iron			
0.5 - 36 L/h	G1/8	DOM-A05H R1	DOM-S05H R1	-	1 = FPM (standard) 2 = EPR 3 = PTFE encaps. 4 = NBR	R0 ⁴ = Reed switch pulse output H0 = Hall sensor (NPN)/ reed switch pulse output HE ⁵ = as HO + ATEX (Exd) D0 = Quad Hall sensor 2 phased outputs (NPN) DE ⁵ = as DO + ATEX (Exd) L0 = 4 ... 20 mA loop powered analogue output LE = as LO + ATEX (Exd) Z1 = dual LCD totaliser, pulse output (ZOD-Z1) Z3 = LCD totaliser, rate, outputs: 4-20 mA, alarm, pulse (ZOD-Z3) Z4 = Electronics "Z3" + ATEX (Exi) Z5 = dual LCD totaliser/rate, outputs: alarm, pulse (ZOD-Z5) B1 = LCD batch controller, totaliser, pulse output (ZOD-B1) M1 = mech. totaliser 3-digit ¹⁾ M3 = mech. totaliser 4-digit ¹⁾ XX = special option, specified in clear text	0 = without A ²⁾ = coupled with air eliminator-strainer ZAL C = cooling fin for LCD electronic D ²⁾ = option A + C R ²⁾ = option A + check valve E ²⁾ = option R + C S ³⁾ = special cut rotors for higher viscosities Y = special option (specify in clear text)
2 - 100 L/h	G1/4	DOM-A10H R2	DOM-S10H R2	-			
15 - 550 L/h	G3/8	DOM-A15H R3	DOM-S15H R3	-			
1 - 40	G1/2	DOM-A20H R4	DOM-S20H R4	-			
10 - 150	G1	DOM-A25H R6	DOM-S25H R6	-			
15 - 250	G1 1/2	DOM-A30H R8	DOM-S30H R8	-			
30 - 450	G2	DOM-A35H R9	DOM-S35H R9	-			
50 - 580	G2	DOM-A40H R9	-	-	1 = FPM (standard) 2 = EPR 4 = NBR		
35 - 750	G3	DOM-A45H RB	DOM-S45H RB	DOM-D45H RB			
50 - 1000	G3	DOM-A50H RB	-	-			
75 - 1500	G4	DOM-A55H RC	-	DOM-D55H RC			
150 - 2500	G4	DOM-A60H RC	-	-			

For NPT connection change "DOM-xxxx Rx..." into "DOM-xxxx Nx"

For PPS rotors (PTFE filled) change "DOM-Axxxx" into "DOM-7xxxx" and "DOM-Sxxxx" into "DOM-8xxxx"

PPS rotors not possible for "DOM-x05,-x10,-x40,-x60 and DOM-D"

¹⁾ not for DOM-x05, -x10, -x15, 3-digit recommended for DOM-x20, -x25, 4-digit recommended for DOM-x25 and larger; ²⁾ not available for DOM-x05, -x10, -x15, -x20, only available for DOM-A.. Option 'R' not available with DOM-A25..; ³⁾ only available for DOM-A20.. to DOM-A60.., DOM-S15.. to DOM-S35.. and DOM-D..; ⁴⁾ should be chosen when using DOM intrinsically safe circuits as "simple apparatus"; ⁵⁾ not available with Ductile iron housing



Order Details Flange Connection (Example: DOM-A45H F8 1 Z3 C)

Meas. range [L/min]	Connection DIN flange PN16	Housing material			O-ring material	Electronics	Option
		Aluminium	Stainless steel	Ductile iron			
10 - 150	DN 25/1"	DOM-A25H F6	DOM-S25H F6	-	1= FPM (standard) 2= EPR 3= PTFE encaps. FPM 4= NBR	R0 ⁴⁾ = Reed switch pulse output H0 = Hall sensor (NPN)/ reed switch pulse output HE ⁵⁾ = as HO + ATEX (Exd) D0 = Quad Hall sensor 2 phased outputs (NPN) DE ⁵⁾ = as DO + ATEX (NPN) L0 = 4...20 mA loop powered analogue output LE = as LO + ATEX (Exd) Z1 = dual LCD totaliser, pulse output (ZOD-Z1) Z3 = LCD totaliser, rate, outputs: 4-20 mA, alarm, pulse (ZOD-Z3) Z4 = Electronics "Z3" + ATEX (Exi) Z5 = dual LCD totaliser/rate, outputs: alarm, pulse (ZOD-Z5) B1 = LCD batch controller, totaliser, pulse output (ZOD-B1) M1 = mech. totaliser 3-digit ¹⁾ M3 = mech. totaliser 4-digit ¹⁾ XX = special option, specified in clear text	0 = without A ²⁾ = coupled with air eliminator-strainer ZAL C = cooling fin for LCD electronic D ²⁾ = option A + C R ²⁾ = option A + check valve E ²⁾ = option R + C S ³⁾ = special cut rotors for higher viscosities Y = special option (specify in clear text)
15 - 250	DN 40/1½"	DOM-A30H F8	DOM-S30H F8	-			
30 - 450	DN 50/2"	DOM-A35H F9	DOM-S35H F9	-			
50 - 580	DN 50/2"	DOM-A40H F9	-	-			
35 - 750	DN 80/3"	DOM-A45H FB	DOM-S45H FB	DOM-D45H FB	1= FPM (standard) 2= EPR 4= NBR	R0 ⁴⁾ = Reed switch pulse output H0 = Hall sensor (NPN)/ reed switch pulse output HE ⁵⁾ = as HO + ATEX (Exd) D0 = Quad Hall sensor 2 phased outputs (NPN) DE ⁵⁾ = as DO + ATEX (NPN) L0 = 4...20 mA loop powered analogue output LE = as LO + ATEX (Exd) Z1 = dual LCD totaliser, pulse output (ZOD-Z1) Z3 = LCD totaliser, rate, outputs: 4-20 mA, alarm, pulse (ZOD-Z3) Z4 = Electronics "Z3" + ATEX (Exi) Z5 = dual LCD totaliser/rate, outputs: alarm, pulse (ZOD-Z5) B1 = LCD batch controller, totaliser, pulse output (ZOD-B1) M1 = mech. totaliser 3-digit ¹⁾ M3 = mech. totaliser 4-digit ¹⁾ XX = special option, specified in clear text	0 = without A ²⁾ = coupled with air eliminator-strainer ZAL C = cooling fin for LCD electronic D ²⁾ = option A + C R ²⁾ = option A + check valve E ²⁾ = option R + C S ³⁾ = special cut rotors for higher viscosities Y = special option (specify in clear text)
50 - 1000	DN 80/3"	DOM-A50H FB	-	-			
75 - 1500	DN 100/4"	DOM-A55H FC	-	DOM-D55H FC			
150 - 2500	DN 100/4"	DOM-A60H FC	-	-			

ANSI-150 RF flange change "DOM-xxxx Fx..." into "DOM-xxxx Ax". ANSI-300 RF flange change "DOM-xxxx Fx..." into "DOM-xxxx Bx" (only 1", 1½, 2")
 For PPS rotors (PTFE filled) change "DOM-Axxxx" into "DOM-7xxxx" and "DOM-Sxxxx" into "DOM-8xxxx".
 PPS rotors not possible for "DOM-x05,-x10,-x40,-x60 and DOM-D

¹⁾ 3-digit recommended for DOM-x25, 4-digit recommended for DOM-x25 and larger; ²⁾ only available for DOM-A... Option 'R' not available with DOM-A25...

³⁾ only available for DOM-A..., DOM-S25... to DOM-S35... and DOM-D; ⁴⁾ should be chosen when using DOM intrinsically safe circuits as "simple apparatus";

⁵⁾ not available with Ductile iron housing

Order Details High Pressure (Example: DOM-H35H R9 1 R0 S)

Meas. range [L/min]	Connection	Housing material stainless steel	O-ring material	Electronics	Option
0.5 - 36 L/h	G½	DOM-H05H R1	1 = FPM (standard) 2 = EPR 3 = PTFE encaps. FPM 4 = NBR	H0 = Hall sensor pulse output (NPN) HE = as HO + ATEX (Exd) R0 = pulse output (reed switch) L0 = 4...20 mA loop powered analogue output LE = as LO + ATEX (Exd) Z1 = dual LCD totaliser, pulse output (ZOD-Z1) Z3 = LCD totaliser, rate, outputs: 4-20 mA, alarm, pulse (ZOD-Z3) Z4 = Electronics "Z3" + ATEX (Exi) Z5 = dual LCD totaliser/rate, outputs: alarm, pulse (ZOD-Z5) B1 = LCD batch controller, totaliser, pulse output (ZOD-B1) XX = special option, specified in clear text	0 = without C = cooling fin for LCD electronic S ¹⁾ = special cut rotors for higher viscosities Y = special option (specify in clear text)
2 - 100 L/h	G¼	DOM-H10H R2			
15 - 550 L/h	G¼	DOM-H15H R2			
1 - 40	G½	DOM-H20H R4			
10 - 150	G1	DOM-H25H R6			
15 - 250	G1½	DOM-H30H R8			
30 - 450	G2	DOM-H35H R9			

For NPT connection change "DOM-xxxx Rx..." into "DOM-xxxx Nx".

For PPS rotors (PTFE filled) change "DOM-Hxxxx" into "DOM-9xxxx" PPS rotors not possible for "DOM-H05xxxx and DOM-H10xxxx

¹⁾ only available for DOM-H15... to DOM-H35...

Dimensions for DOM-A(S)...

DOM-x05 DOM-x15

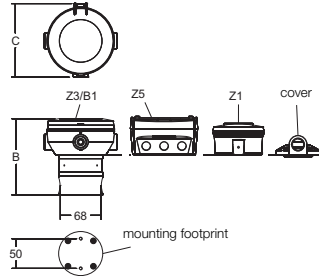

DOM-H05 DOM-H20

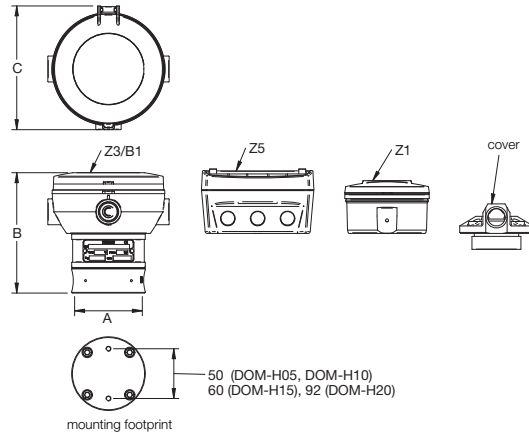

DOM-x20 DOM-x40

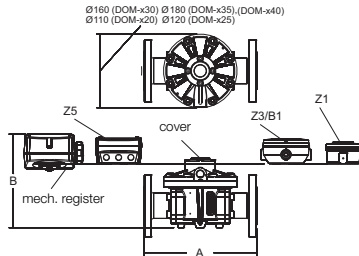

DOM-H25 DOM-H35

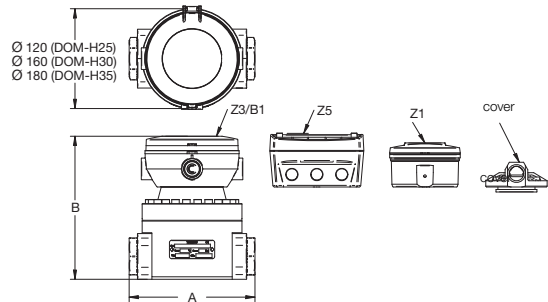

DOM-x45 DOM-x60

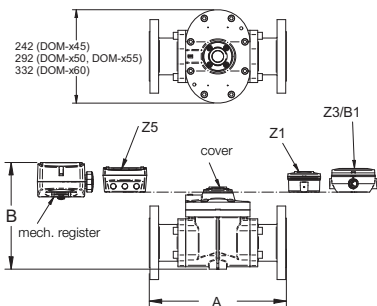

Dimensions for DOM-A(S)[H]... (± 2 mm)

Model	A (mm)		B (mm)					C (mm)			
	Thread connection	Flange connection	Cover	Z1	Z3, B1	Z5	M1 M3	Cover	Z1	Z3, B1	Z5
DOM-x05	- [68]	-	92 [90]	113 [113]	122 [121]	125 [125]	-	72 [74]	94 [94]	124 [124]	96 [96]
DOM-x10	- [68]	-	92 [90]	113 [113]	122 [121]	125 [125]	-	72 [74]	94 [94]	124 [124]	96 [96]
DOM-x15	- [95]	-	99 [117]	120 [140]	129 [148]	132 [152]	-	72 [100]	94 [100]	124 [124]	96 [100]
DOM-x20	110 [112]	-	106 [122]	145 [145]	154 [153]	157 [157]	178	[120]	[120]	[124]	[120]
DOM-x25	137 (176) [152]	198 (237)	120 [141]	160 [164]	168 [172]	172 [176]	188	[120]	[120]	[120]	[120]
DOM-x30	188 [217]	252	155 [165]	195 [188]	203 [196]	207 [200]	227	[160]	[160]	[160]	[160]
DOM-x35	212 [236]	274 ¹⁾ (277)	170 [187]	210 [210]	218 [218]	222 [222]	237	[180]	[180]	[180]	[180]
DOM-x40	212	274 ¹⁾	220	260	268	271	286	-	-	-	-
DOM-x45	266	354	213 (206)	252 (249)	260 (257)	264 (260)	270	-	-	-	-
DOM-x50	294	382	229	269	277	281	288	-	-	-	-
DOM-x55	294	388	274	314	322	326	333	-	-	-	-
DOM-x60	320	414	352	391	399	403	415	-	-	-	-

Note: Dimensions of DOM-D-45/55 are same as those of DOM-A-45/55, Dimensions for DOM-S... are specified in () only when they are different from DOM-A, Dimensions of DOM-H... are specified in [].

¹⁾ Dimensions for DIN flanges, 272 mm for ANSI flanges

Dimensions for DOM-A25... DOM-A40 with option "A"

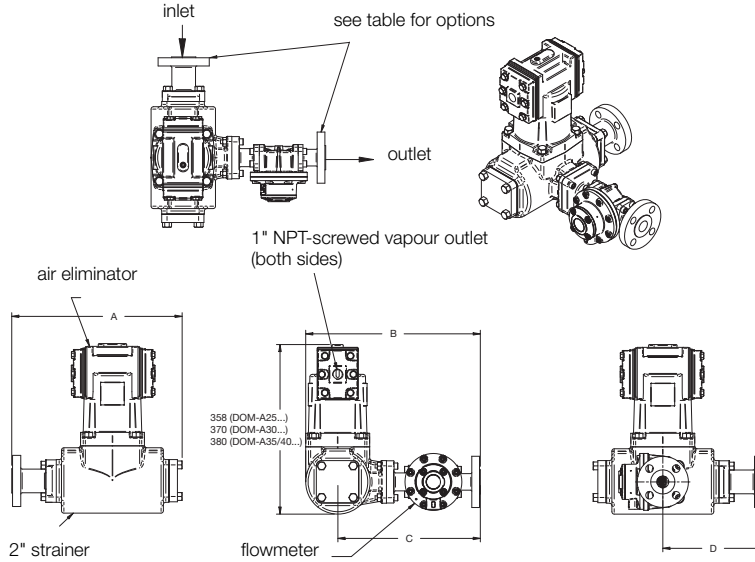

Dimensions for DOM-A45... DOM-A60 with option "A"

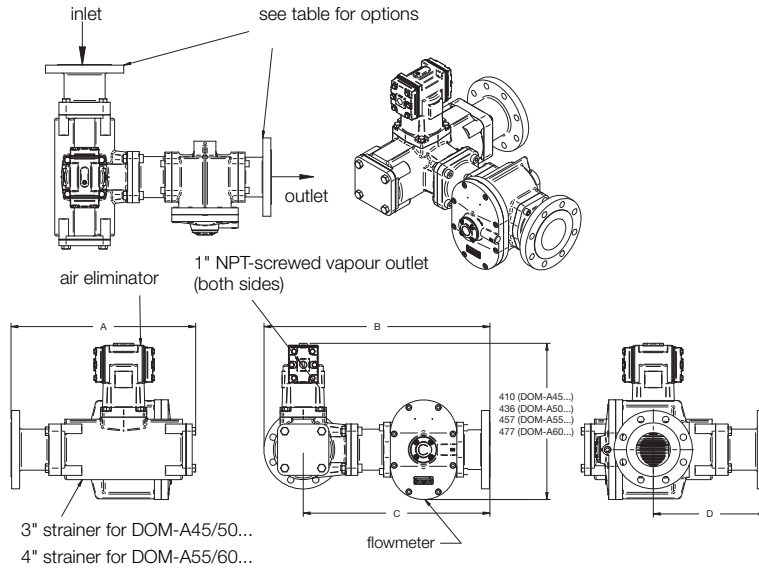

Dimensions for DOM-A... with option "A" (± 2 mm)

Model	Thread connection (G or NPT)				Flanged connection (DIN PN16 or ANSI 150RF)			
	A	B	C	D	A	B	C	D
DOM-A25	298	338	270	151	360	368	300	213
DOM-A30	288	400	291	141	360	432	363	213
DOM-A35	300	429	353	141	360*	459*	383*	213*
DOM-A40	300	429	353	141	360*	459*	383*	213*
DOM-A45	326	507	439	161	421	578	483	265
DOM-A50	326	535	467	161	421	606	511	265
DOM-A55	439	586	499	219	540	660	546	329
DOM-A60	439	612	525	219	540	686	572	329

* +1mm for DIN flanges