

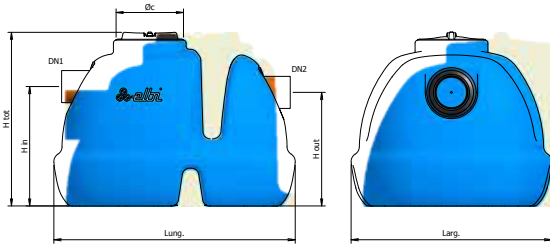

# DG / DG-PRO WASTEWATER TREATMENT

POLYETHYLENE SAND \ GREASE TRAPS FOR UNDERGROUND

## DG 5 - 20



## DG-PRO 45 - 350

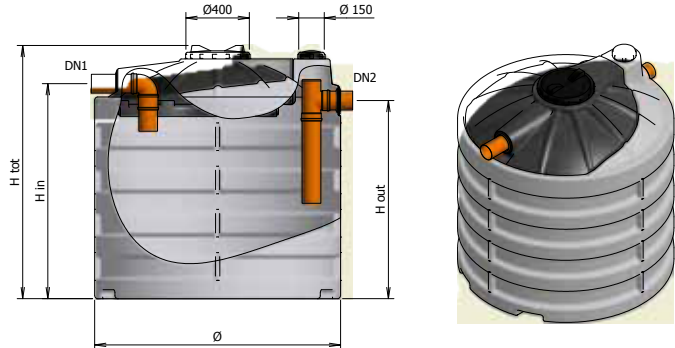

Not for drinking water



Model for underground only  
(DG-PRO 45 - 350)



Handling by forklift



Above ground only  
(DG 5 - 20)

Use:

Primary treatment of residential grey water.

The sand/grease trap is installed near the kitchen drains, laundry and bathroom to separate grease, foam, vegetable and animal fats and other solid particles in the waste water.

Operation:

The system takes advantage of gravity to eliminate all those solid particles characterized by a specific weight greater than that of water such as to deposit on the bottom of the tank. Furthermore, for flotation, oils, fats and substances with specific weight lower than water get separated from each other; this phenomenon reduces the presence of oily substances which tend to coat biological materials thus preventing oxidation.

Maintenance:

You are advised to inspect the sand/grease traps at least once a year. If you find excess sludge and/or deposits present, contact specialist companies to remove the solid sediments and the greasy/oily parts that sticks to the inner walls.

Specifications item:

Sand/grease trap manufactured in rotational polyethylene, in a single structure without joints and equipped with inlet and outlet pipes, and lid for inspection and sampling.

Suitable for underground installation.

Reference standard:

Compliance with standard EN 1825-1 and Legislative Decree no. 152/2006. CE pending

WARRANTY: 2 YEARS

## DIMENSIONS

| MODEL | CODE    |       |           |          |           |           |                         |                            |                           |     | DN1/DN2<br>mm | ЦЕНА (в лева с ДДС) |
|-------|---------|-------|-----------|----------|-----------|-----------|-------------------------|----------------------------|---------------------------|-----|---------------|---------------------|
|       |         | P.E.  | TOT<br>mm | IN<br>mm | OUT<br>mm | mm        | fat<br>volume<br>LITRES | sludge<br>volume<br>LITRES | total<br>volume<br>LITRES |     |               |                     |
| DG 5  | A500005 | 2-6   | 600       | 410      | 390       | 830x690   | 10                      | 25                         | 95                        | 110 | 302,00        |                     |
| DG 10 | A500010 | 7-11  | 710       | 520      | 500       | 995x825   | 20                      | 50                         | 190                       | 110 | 332,00        |                     |
| DG 15 | A500015 | 12-16 | 795       | 605      | 585       | 1135x945  | 30                      | 75                         | 285                       | 110 | 369,00        |                     |
| DG 20 | A500020 | 17-21 | 875       | 685      | 665       | 1255x1040 | 40                      | 100                        | 380                       | 110 | 432,00        |                     |

| MODEL      | CODE    |         |           |          |           |      |                         |                            |                           |     | DN1/DN2<br>mm |  |
|------------|---------|---------|-----------|----------|-----------|------|-------------------------|----------------------------|---------------------------|-----|---------------|--|
|            |         | P.E.    | TOT<br>mm | IN<br>mm | OUT<br>mm | mm   | fat<br>volume<br>LITRES | sludge<br>volume<br>LITRES | total<br>volume<br>LITRES |     |               |  |
| DG-PRO 45  | A500045 | 30-52   | 1240      | 1030     | 935       | 1310 | 90                      | 225                        | 853                       | 110 | 1053,00       |  |
| DG-PRO 60  | A500060 | 53-70   | 1500      | 1290     | 1195      | 1310 | 120                     | 300                        | 1170                      | 110 | 1140,00       |  |
| DG-PRO 75  | A500075 | 71-85   | 1760      | 1550     | 1455      | 1310 | 150                     | 375                        | 1490                      | 110 | 1228,00       |  |
| DG-PRO 110 | A500110 | 86-110  | 1700      | 1445     | 1330      | 1650 | 220                     | 550                        | 2170                      | 125 | 1638,00       |  |
| DG-PRO 140 | A500140 | 111-135 | 1990      | 1735     | 1620      | 1650 | 280                     | 700                        | 2740                      | 125 | 1813,00       |  |
| DG-PRO 170 | A500170 | 136-185 | 2280      | 2025     | 1910      | 1650 | 340                     | 850                        | 3310                      | 125 | 1989,00       |  |
| DG-PRO 240 | A500240 | 186-265 | 1900      | 1605     | 1475      | 2270 | 480                     | 1200                       | 4710                      | 160 | 4095,00       |  |
| DG-PRO 350 | A500350 | 266-370 | 2430      | 2130     | 2000      | 2270 | 700                     | 1750                       | 6710                      | 160 | 5118,00       |  |